

# Product datasheet

Dock leveller  
Crawford DL6010S

**ASSA ABLOY**

ASSA ABLOY Entrance Systems

The global leader in  
door opening solutions

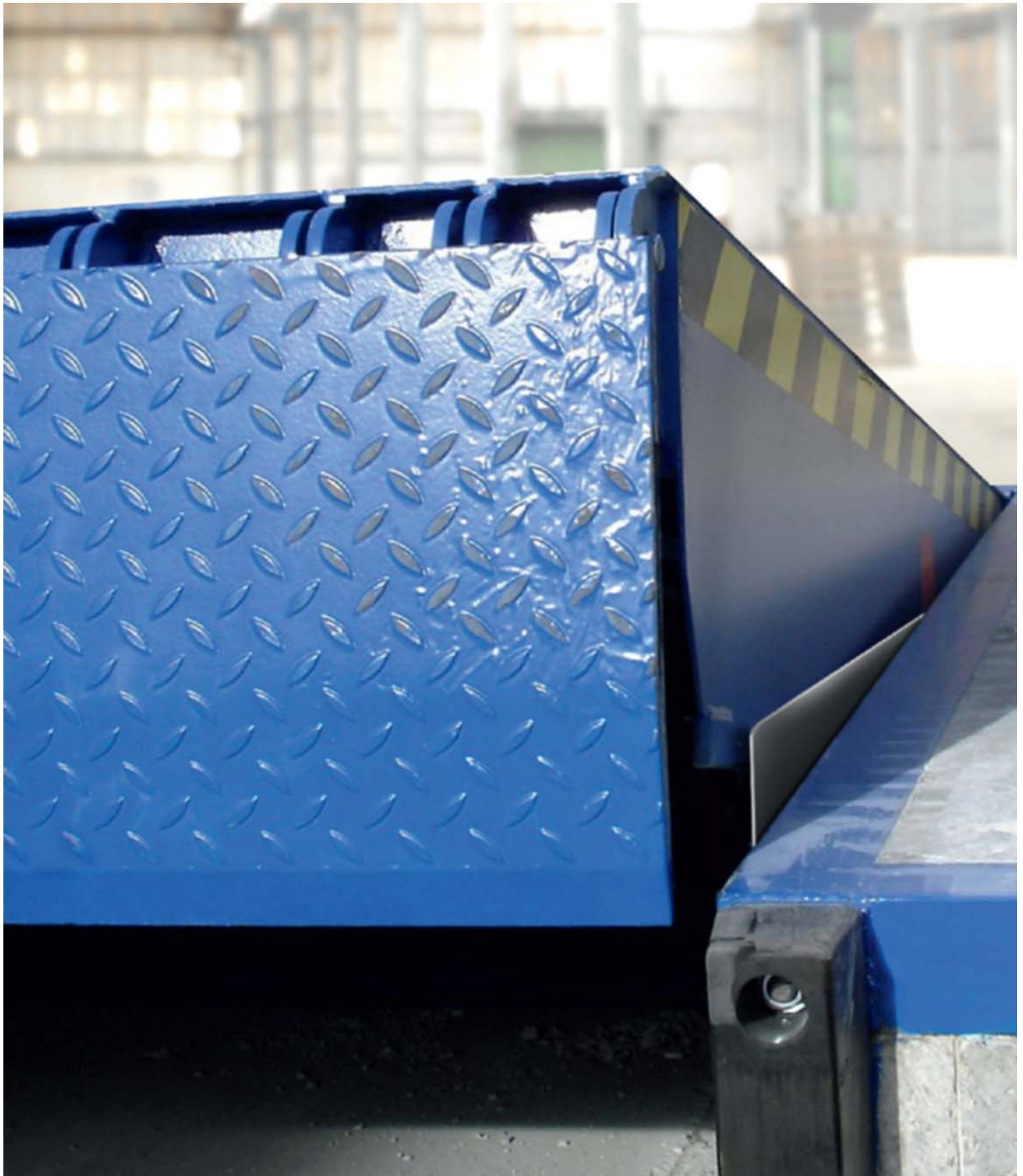

# Copyright and Disclaimer Notice

Although the contents of this publication have been compiled with the greatest possible care, ASSA ABLOY Entrance Systems cannot accept liability for any damage that might arise from errors or omissions in this publication. We also reserve the right to make appropriate technical modifications/replacements without prior notice.

No rights can be derived from the contents of this document.

Color guides: Color differences may occur due to different printing and publication methods.

ASSA ABLOY, Besam, Crawford, Megadoor and Albany, as words and logos, are examples of trademarks owned by ASSA ABLOY Entrance Systems or companies within the ASSA ABLOY Group.

Copyright © ASSA ABLOY Entrance Systems AB 2006-2014.

No part of this publication may be copied or published by means of scanning, printing, photocopying, microfilm or any other process whatsoever without prior permission in writing by ASSA ABLOY Entrance Systems.

All rights reserved.

# Technical facts

## Features

Sizes - nominal length*	2000, 2250, 2500, 2770, 3000, 3500, 4000, 4500 mm	
Sizes - nominal width	1750, 2000, 2200 mm	
Vertical working range	Above dock:	0 - 570 mm
	Below dock:	0 - 350 mm
Platform tear plate	Standard:	Thickness: 6 mm (6/8)
	Option:	Thickness: 8 mm (8/10)
Surface treatment:	Standard:	RAL 5010
	Option:	RAL 3002
		RAL 6005
		RAL 9005
		Hot dip galvanised
Control Unit	Leveller control Door control Shelter control Fault & service indicator	

\* Other sizes are available on request

## Performance

Load capacity:	6 tonnes (60kN)
Max. point load:	1,3 N / mm <sup>2</sup> (6 mm tear plate)
Motor hydraulic unit:	0,75 kW
Mains supply:	400V 3-phase, 230V 3-phase
Control unit protection class:	IP 54
Allowable oil types:	Crawford standard hydraulic oil (-20°C - +60°C) Crawford low temperature hydraulic oil (-30°C - +60°C) Crawford bio hydraulic oil (-20°C - +60°C)
Magnetic valves:	24V/DC 18W S1
Surface treatment paint class 1:	80 µm Corrosive Category C2 M acc. DIN EN ISO 12944-2
Surface treatment paint class 3:	160 µm Corrosive Category C3 M acc. DIN EN ISO 12944-2
Surface treatment galvanised:	Hot dip galvanised 80 µm Corrosive category C4 & C5-I M acc. DIN EN ISO 12944-2

# Contents

Copyright and Disclaimer Notice .....	2
Technical facts .....	3
Contents .....	4
1. Description .....	6
1.1 General.....	6
1.1.1 Application.....	6
1.1.2 Mode of operation .....	6
1.1.3 Overview.....	6
1.1.4 Standard.....	6
1.1.5 Options.....	6
1.2 Swing Lip.....	7
1.2.1 Lip shapes .....	7
1.2.2 Lip angles .....	7
1.3 Platform .....	8
1.3.1 Platform tear-plate thickness .....	8
1.3.2 Toe guards.....	8
1.3.3 EPDM seal .....	8
1.3.4 Slip protection / noise reduction .....	8
1.3.5 Platform insulation.....	8
1.4 Surface.....	9
1.4.1 Painting .....	9
1.4.2 Hot galvanising.....	9
1.5 Frames - connection to building.....	9
1.5.1 T - leveller frame for embedding in concrete.....	9
1.5.2 T - 200 leveller frame for embedding in concrete .....	9
1.5.3 W - leveller frame for welding.....	10
1.5.4 F - flat frame for welding .....	10
1.5.5 P - pit frame for welding.....	10
1.5.6 B - box-frame.....	10
1.6 Docking control systems .....	11
1.6.1 950 Docking L SD.....	11
1.6.2 950 Docking LA SD.....	11
1.6.3 950 Docking DLA SD .....	11
1.6.4 950 Docking LSA SD .....	11
1.6.5 950 Docking DLSA SD .....	11
1.7 Monitoring systems .....	12
1.7.1 Saving energy .....	12
1.7.2 Security enhancement .....	12
1.7.3 Dock management .....	12
1.7.4 Facility management .....	12
1.8 Equipment.....	12
1.8.1 Buffers.....	12
1.8.2 Crawford DE6090E Eye .....	13
1.8.3 Crawford DE6090WC Wheel chock.....	13
1.8.4 Crawford DE6090TS Traffic light system.....	13
1.8.5 Crawford DE6090DL Dock light Heavy Duty LED .....	14
1.8.6 Parking guides.....	14
1.8.7 Crawford DE6090DI Dock-IN .....	14

2.	Selection guide .....	15
2.1	Load capacity according to EN 1398 .....	15
2.1.1	Rated load .....	15
2.1.2	Axle load .....	15
2.1.3	Dynamic load .....	15
2.2	Select the load capacity .....	15
2.2.1	Example .....	15
2.3	Select the appropriate platform tear plate thickness .....	16
2.3.1	Handling equipment traffic situation.....	16
2.3.2	Example .....	16
2.4	Select the leveller length .....	16
2.4.1	The calculation .....	16
2.4.2	Example .....	16
2.5	Nominal width.....	16
3.	Specifications .....	17
3.1	Dimensions.....	17
3.2	Platform thickness.....	17
3.3	Control units .....	18
3.3.1	Dimensions.....	18
3.3.2	Functions .....	18
4.	CEN Performance .....	19
4.1	Safety according to the European Standard EN 1398 .....	19
5.	Building and space requirements .....	20
5.1	Electrical preparations.....	20
5.2	Pit preparations.....	21
5.2.1	T - frame + T-frame 200.....	21
5.2.2	W - frame .....	21
5.2.3	F - frame .....	22
5.2.4	P - frame .....	22
5.2.5	B - frame.....	23
6.	Service .....	24
	Index .....	25

# 1. Description

## 1.1 General

### 1.1.1 Application

The Crawford DL6011S swingdock 100 is the standard solution in general industry applications and easy to operate. The Crawford DL6011S swingdock 100 system meets the standard demands of most loading operations and fully complies with rules and regulations of the European Standard EN 1398.

### 1.1.2 Mode of operation

The swing lip safely bridges the gap between the ramp and the lorry bed. When the dock leveller is raised, the lip swings out and the leveller lowers gently onto the lorry bed. After loading or unloading, the leveller is raised again, the lip swings down and the platform returns to its parking position, i.e. to ramp level.

### 1.1.3 Overview

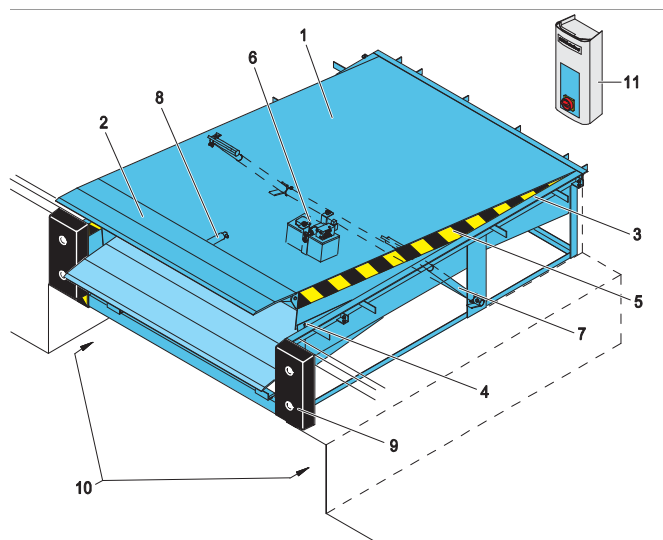

- 1 Leveller platform
- 2 Swing lip
- 3 Leveller frame
- 4 Toe guards
- 5 Warning stripes
- 6 Hydraulic unit
- 7 Lift cylinders
- 8 Swing lip cylinder
- 9 Buffers (option)
- 10 Tail lift recess
- 11 Control unit

### 1.1.4 Standard

Frames - connection to building:	P-frame [pit-frame]
Surface	Painting RAL 5010
Hydraulic Equipment	Low noise hydraulic unit Two hydraulic lift cylinders One hydraulic lip cylinder
Lip	Lip length 400 mm Bevelled 40 mm Bent lip

### 1.1.5 Options

Frames - connection to building	T-200 frame W-frame [frame for welding] F-frame [flat frame for welding] P-frame [pit-frame, max NL=3000] B-frame [box-frame]
Surface	Painting RAL 3002, RAL 6005 or RAL 9005 Hot galvanised
Hydraulic equipment	Low temperature oil Bio oil
Lip options	Lip length 500mm [only LH>600] Lip bevelled, 100 mm Straight lip 2 fold down segments Tapered lip
Energy & Ergonomics	EPDM seal* 40 mm platform insulation Slip protection / noise reduction

\* Not available for frame P

## 1.2 Swing Lip

### 1.2.1 Lip shapes

#### 1.2.1.1 Standard swing lip

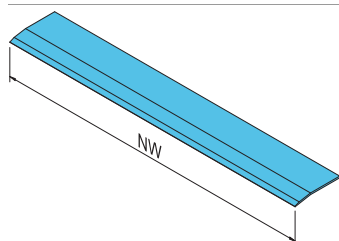

The standard swing lip is a single rectangular lip for use with a fleet of vehicles that is a standard size.

#### 1.2.1.2 Tapered swing lip

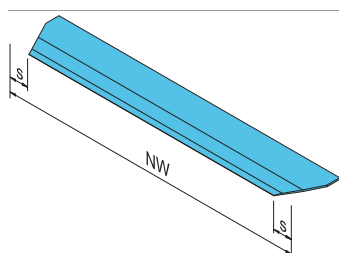

A tapered swing lip ensures that the lip reaches the lorry bed, even when the lorry is not parked in the exact centre position. Avoids damage to the truck and interruptions of the dock-in procedure.  $s = 125 \text{ mm}$

#### 1.2.1.3 Fold down segments

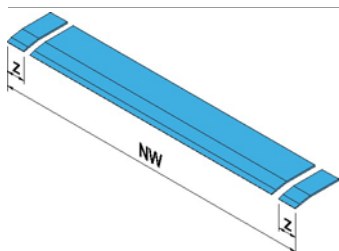

Ensures that the swing lip reaches the lorry bed by folding down one or both outer segments when the lorry is smaller than usual, or not parked in the exact centre position. Avoids damage to the truck and interruption of the dock-in procedure. Only available for 60 kN.  $Z = 125 \text{ mm}$

### 1.2.2 Lip angles

#### 1.2.2.1 Bent lip

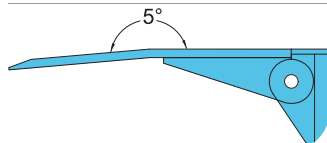

The standard bent steel swing lip ensures smooth transition to a lorry bed both above and below dock level. Avoids tripping hazards according to EN 1398.

#### 1.2.2.2 Straight lip

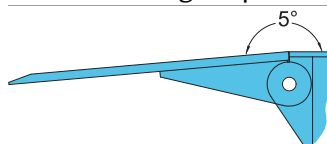

A straight steel swing lip ensures smooth transition when the lorry bed is below or equal to dock level. Avoids tripping hazards according to EN 1398.

#### 1.2.2.3 Bevelled lip

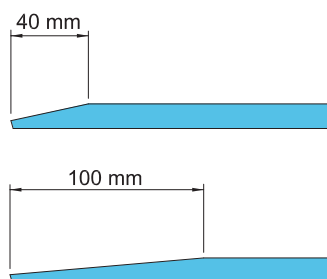

The standard steel lip is 40 mm bevelled. Optionally, the lip can be bevelled 100 mm, designed to provide maximum comfort and smooth transition from the lip.

## 1.3 Platform

### 1.3.1 Platform tear-plate thickness

The 6 mm (6/8) tear-plate is designed for loading and unloading with typical 4 wheel pneumatic-tired fork-lift trucks. Alternatively an 8 mm (8/10) tear-plate is available for handling equipment with high point loads, such as electric pallet trucks. However, potential platform deformations do not reduce the functionality of the leveller.

### 1.3.2 Toe guards

The leveller is as standard equipped with toe guards; steel plates between the platform and the frame. The toe guard prevents the pinching of feet when the leveller is lowered.

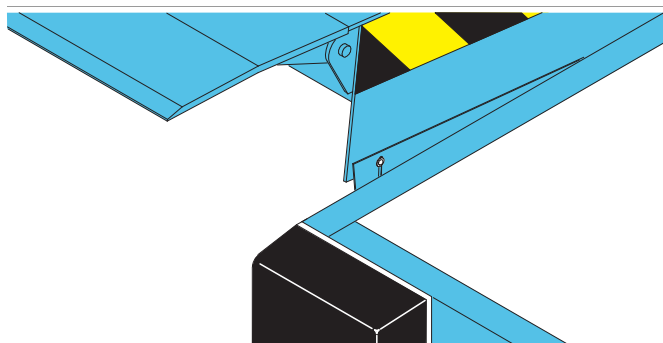

### 1.3.3 EPDM seal

To seal the gap between leveller and pit, an EPDM seal can be factory-installed between the flexible platform and frame. By reducing draughts into the building, working conditions improve and energy savings increase.

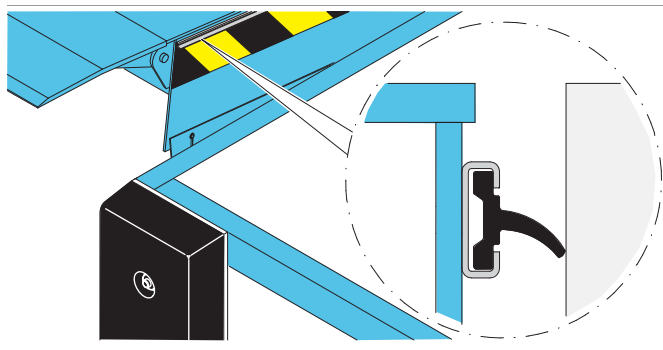

\*not in combination with P-frame.

### 1.3.4 Slip protection / noise reduction

Applying a polyurethane slip protection coating on the lip and platform ensures a durable non-slip and noise reduction surface. The effect is a smooth and comfortable surface for handling equipment that is less receptive to wear and tear.

The PU coating material is resistant to impact, to thermal impact and most types of chemicals and it has a high loading capacity.

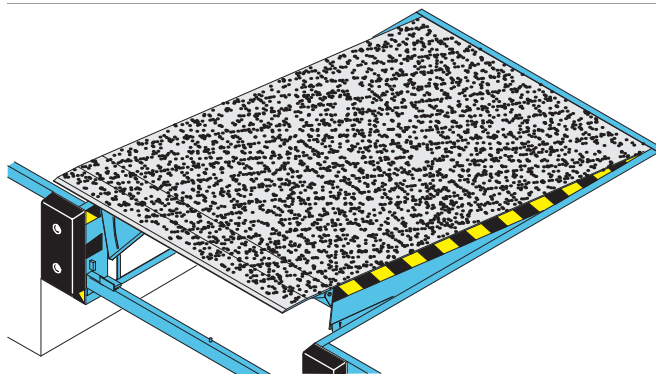

### 1.3.5 Platform insulation

When the dock leveller is positioned in a bay directly outside the door opening, it can be beneficial to insulate the dock leveller. The insulation counteracts the penetration of incoming heat/cold from outside. To achieve the best results, the dock leveller should also be fitted with an EPDM seal.

The insulation consists of factory-installed insulated panels with a thickness of 40 mm.

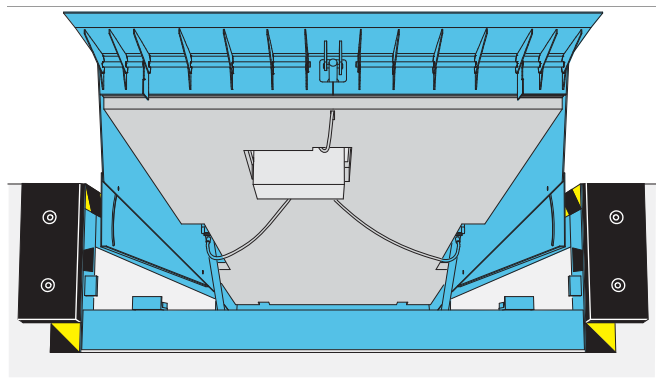



## 1.4 Surface

### 1.4.1 Painting

#### 1.4.1.1 Colours

The dock leveller standard finish is painted. The standard colour is:



Colours available as option are:

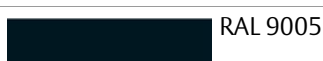

#### 1.4.1.2 Standard paint class

If the dock leveller is to be used in a rural area, the standard finish is:

- Paint class 1; 80 µm factory painted for corrosive category C2 M

#### 1.4.1.3 Paint classes

If the dock leveller is to be used in an urban or industrial atmosphere, or in a coastal area, it may be appropriate to select an alternative paint class with increased resistance to corrosion C3 M.

- Paint class 3; 160 µm factory painted for corrosive category C3 M

### 1.4.2 Hot galvanising

To increase corrosion protection to C4 for saline coastal areas or C5-I for aggressive or humid atmospheres, the dock leveller can be delivered with hot dip galvanised (80 µm) steel parts.

## 1.5 Frames - connection to building

The frame is the leveller's connection point to the building and a rigid support for the leveller.

The Crawford DL6010S swingdock is available with different frame types. The frame can be embedded in concrete or installed via screws or welding. All frames are illustrated with the tail lift recess. The levellers are also available without tail lift recess.

### 1.5.1 T - leveller frame for embedding in concrete

The T-frame is installed in one step. The leveller is directly embedded in concrete.

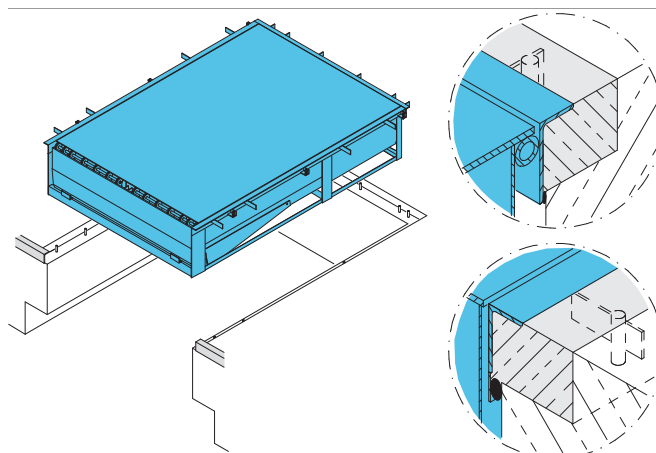

### 1.5.2 T - 200 leveller frame for embedding in concrete

The rear vertical part of the T-frame is prolonged from 100 mm to 200 mm to improve the situation during the process of pouring the concrete to finish floor level in the building, when the dock edge gap of the concrete pit is not fully in line with out pit drawing.

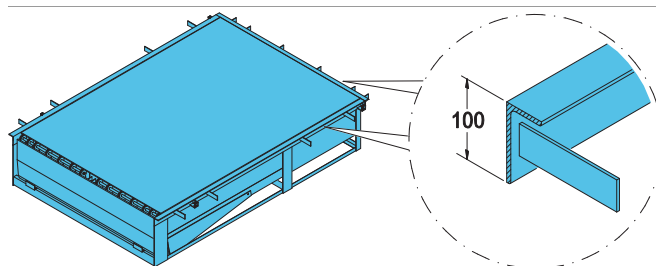

T-frame (standard) 100 mm

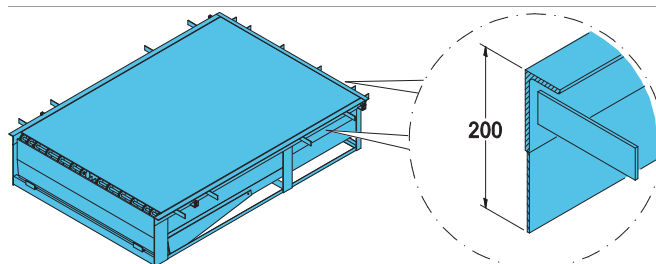

T-frame (option) 200 mm

### 1.5.3 W - leveller frame for welding

The W-frame is designed to weld the leveller directly to the floor slab. In case of future replacement, the welding points can be ground away.

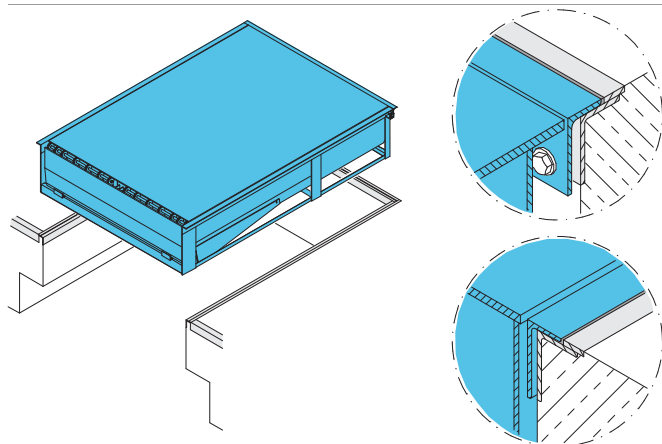

### 1.5.4 F - flat frame for welding

The F-frame is designed to weld the leveller directly to the floor slab. In case of future replacement, the welding points can be ground away.

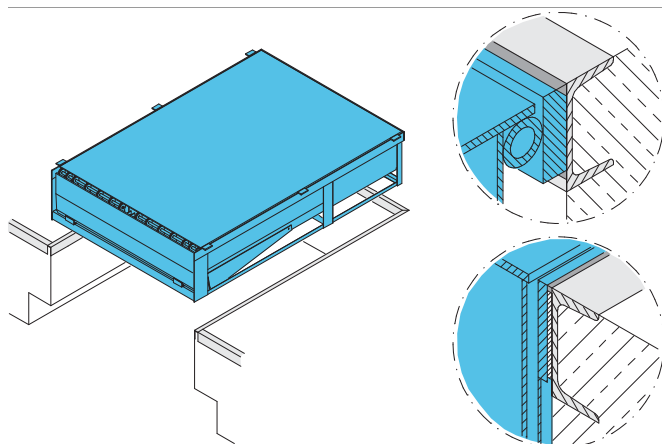

### 1.5.5 P - pit frame for welding

The P-frame leveller is designed to rest on a sturdy concrete slab at the rear of the pit. The rest of the leveller is welded to the pit edges. This leads to fast installation and replacement.

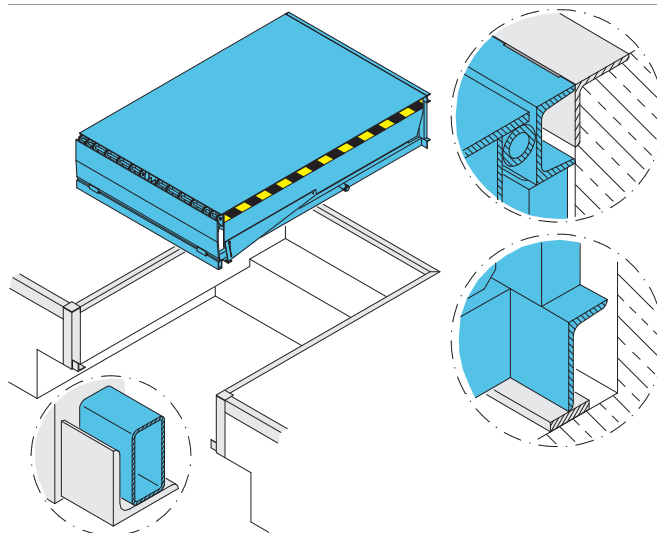

### 1.5.6 B - box-frame

The B-frame is designed to function as the concrete shutter. Therefore complicated and expensive shutter work is not required.

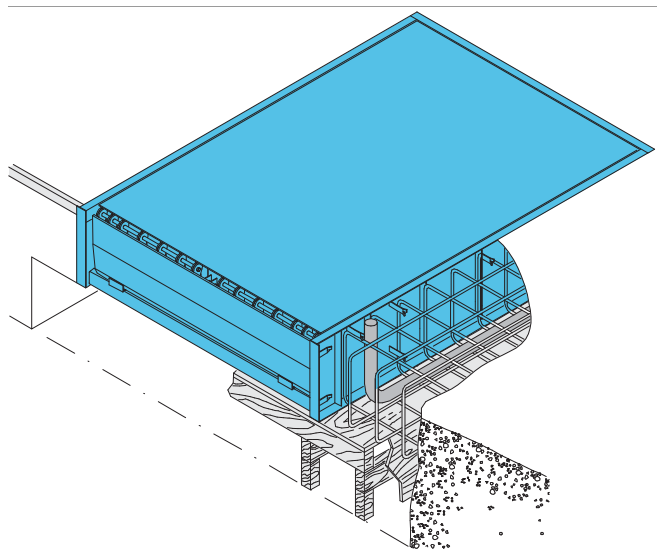

## 1.6 Docking control systems

### 1.6.1 950 Docking L SD

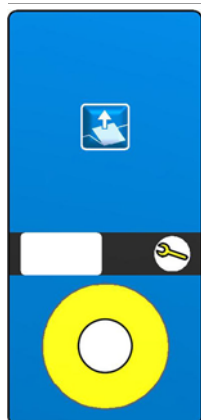

- Hold-to-run button to position the lip on the truck bed.
- Hold-to-run button to put the leveller back in parking position.
- Mains isolator or emergency stop button.
- Interface to incorporate Crawford Eye and/or wheel chock.

### 1.6.4 950 Docking LSA SD

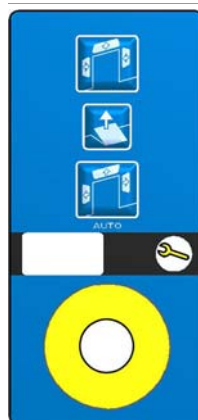

Designed to operate an overhead sectional door and an inflatable shelter in the docking station.

- Hold-to-run button to position the lip on the truck bed.
- Impulse auto button to put the leveller back in parking position.
- Mains isolator or emergency stop button.
- Interface to incorporate Crawford Eye and/or wheel chock.
- Designed to operate an inflatable shelter in the docking station.

### 1.6.2 950 Docking LA SD



- Hold-to-run button to position the lip on the truck bed.
- Impulse auto button to put the leveller back in parking position.
- Mains isolator or emergency stop button.
- Interface to incorporate Crawford Eye and/or wheel chock.

### 1.6.5 950 Docking DLSA SD



Designed to operate an overhead sectional door and an inflatable shelter in the docking station.

- Hold-to-run button to position the lip on the truck bed.
- Impulse auto button to put the leveller back in parking position.
- Mains isolator or emergency stop button.
- Interface to incorporate Crawford Eye and/or wheel chock.
- Designed to operate an overhead sectional door and an inflatable shelter in the docking station.

### 1.6.3 950 Docking DLA SD



Designed to operate an overhead sectional door and an inflatable shelter in the docking station.

- Hold-to-run button to position the lip on the truck bed.
- Impulse auto button to put the leveller back in parking position.
- Mains isolator or emergency stop button.
- Interface to incorporate Crawford Eye and/or wheel chock.

## 1.7 Monitoring systems

As an option on all our products, a Crawford Monitoring System can be installed. This system helps to ensure efficiency and security in daily operations. All doors or docking stations are connected to the Monitoring System's server, which gives the opportunity to supervise, monitor and report a wide variety of aspects in a facility.



### 1.7.1 Saving energy

A monitoring system reduces energy costs and contributes to a better environment. Energy is lost every time a door is open. If a door is open when no truck is at the bay, even more energy is lost.

A Crawford Monitoring System automatically ensures that no door will open unless there is a truck at the bay and even set it to close when there an activity is delayed.

### 1.7.2 Security enhancement

Closing and locking doors is an obvious daily routine. However, checking this manually can be time consuming in a busy facility.

A Crawford Monitoring System can automatically ensure that all doors are closed and locked when they need to be. It can also activate all doors and locks from its remote location, and give a real-time overview of the building's situation.

### 1.7.3 Dock management

A good way to increase throughput and thereby efficiency at a logistics facility is to reduce the time of having no truck – or the wrong truck – at a loading bay.

A Crawford Monitoring System makes visible – in real-time – which bays are occupied or free, and for how long. It makes it possible to reserve bays for docking activities and to inform drivers via SMS. Since it incorporates information from cameras and other inputs (RFID, card readers, etc.), the system stays updated in real-time.

### 1.7.4 Facility management

The Crawford Monitoring System gives a real-time service status for all your door and docking equipment. If an error code occurs, the Crawford service organisation is automatically notified, and will respond quickly. Other maintenance information can easily be integrated, further reducing the overall costs.

## 1.8 Equipment

### 1.8.1 Buffers

Buffers placed in front of the dock leveller absorb the energy of a vehicle that accidentally or intentionally hits the building. Buffers are available in various sizes, in fixed or moving models, and with rubber finishing or steel plate and spring function.

#### 1.8.1.1 RS

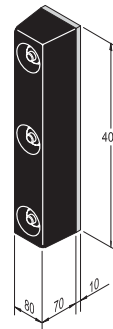

#### Application

The RS buffer is the economical solution for docking stations where vehicles of equal sizes load and unload.

#### 1.8.1.2 RB

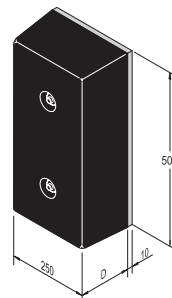

#### Application

The RB buffer is a large fixed rubber. It is the universal building and vehicle protection solution.

Available depths:

- 90 mm
- 140 mm

#### 1.8.1.3 RB with steel front plate

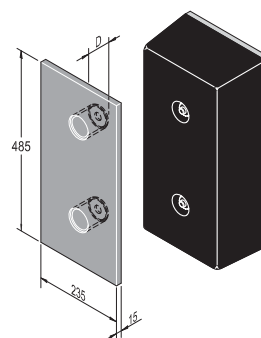

#### Application

The RB buffer with steel protection front plate increases the building protection and the buffer service life.

Available depths:

- 90 mm
- 140 mm

### 1.8.1.4 RB with steel front and top plate

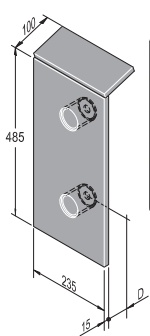

#### Application

The RB buffer with steel protection front and top plate is designed for vehicles with high lorry beds like interchangeable open bodies and containers.

Available depths:

- 90 mm
- 140 mm

### 1.8.1.8 Steel spring buffer 800

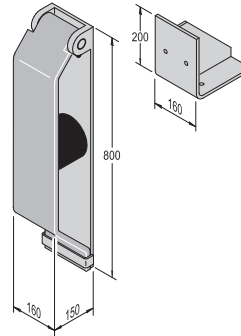

#### Application

The 800 mm steel spring buffer is designed for applications where vehicles generally are higher than ramp level.

### 1.8.1.5 EBF

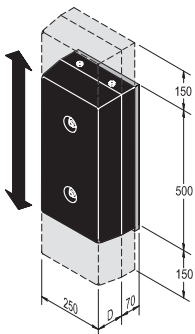

#### Application

The EBF buffer is the ideal solution for docking stations where vehicles are expected to make notable vertical suspension changes when loading or unloading. This buffer follows vertical movements of the vehicle.

Available depths:

- 90 mm
- 140 mm

### 1.8.2 Crawford DE6090E Eye

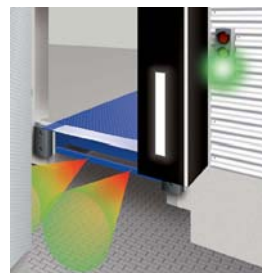

The Crawford Eye is an electronic, sensor-based dock-in system, which measures the distance between the vehicle and the building. This makes it easier for the driver to complete the dock-in procedure, but also detects objects or people behind the vehicle.

### 1.8.1.6 EBH

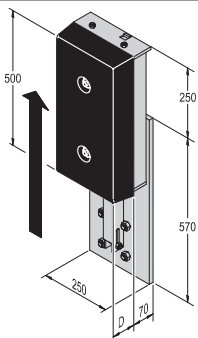

#### Application

The EBH buffer is the ideal solution for docking stations where vehicles of notable height differences load and unload. This buffer can be vertically adjusted by a 'release device'.

Available depths:

- 90 mm
- 140 mm

### 1.8.3 Crawford DE6090WC Wheel chock

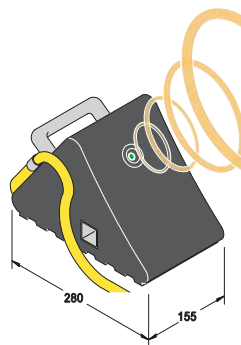

The wheel chock has a sensor to detect the presence and position of the vehicle and is connected to the dock leveller control panel. If no vehicle is detected, the docking station is blocked for safety reasons. Furthermore, the wheel chock prevents the vehicle from moving during loading/unloading.

### 1.8.1.7 Steel spring buffer 600

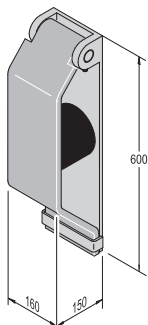

#### Application

The steel spring buffer is the ideal protector of the ramp as well as the vehicle itself.

### 1.8.4 Crawford DE6090TS Traffic light system



The traffic light system either has a sensor above the dock leveller that measures the presence of the vehicle or it is a wheel chock that detects the vehicle.

If there is no vehicle (dock leveller is free), the traffic light inside is red, outside is green.

The traffic light can also be combined with a wheel chock, Crawford Eye or door/leveller interlocking.

### 1.8.5 Crawford DE6090DL Dock light Heavy Duty LED

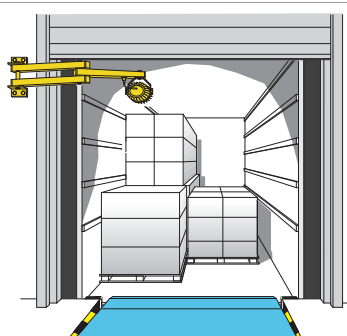

Where dock lights are often a vulnerable object in the docking area, the virtually indestructible Dock Light Heavy Duty LED is the perfect solution to bring light in the truck and docking area. It is designed for the most demanding environments and can withstand possible hard hits from a moving forklift without being damaged.

### 1.8.6 Parking guides

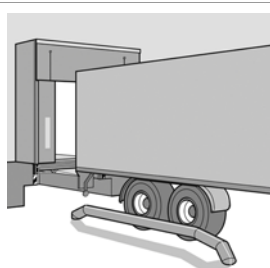

This visual aid makes it easier to park the vehicle and reduces the risk of collision. Especially advantageous for docking stations with wide leveller lips and cushion shelters. Parking guides can be bolted or cast in concrete on the floor before the leveller.

### 1.8.7 Crawford DE6090DI Dock-IN

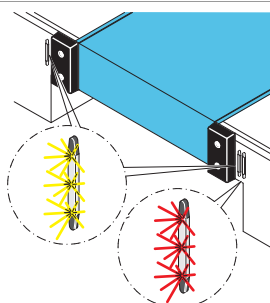

Crawford Dock-IN offers a complete line of guide- and traffic lights that align the truck with the docking bay to make the dock-in procedure easy and safe. Crawford Dock-IN is based on modern LED technology and stands for high reliability and low energy consumption.

#### 1.8.7.1 Dock-IN White

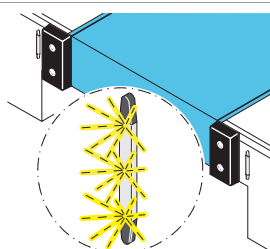

Crawford Dock-IN White consists of two white LED light bars. It is designed to help guide a truck to the dock. Crawford Dock-IN White offers much more visual aid than white stripes on the shelter or asphalt. Mounted on the wall they are always clearly visible, less exposed to wear and tear and not hidden by dirt and snow!

#### 1.8.7.2 Dock-IN Red

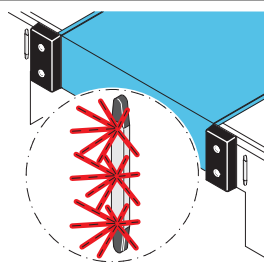

Crawford Dock-IN Red is a traffic light system consisting of one red LED light bar, a sensor for truck detection and a traffic light control box. The sensor detects the truck when it is in the right position, very close to the dock. The red LED turns ON to give the signal to the truck driver to break and let the truck roll against the buffer at the lowest speed, without the risk of damage. The system includes interlocking of the loading bay control box functions which are only released when the truck is in place and the red LED is ON.

#### 1.8.7.3 Dock-IN White & Red

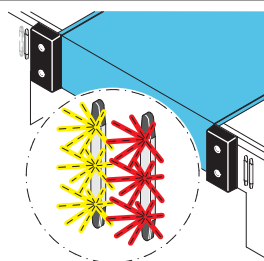

Crawford Dock-IN White & Red is the optimum combination of both systems for easy and safe docking. The white LEDs provide the visual target and the red LED positions the truck at the right distance to the dock. The white guiding LEDs turn off when the truck is detected and at the same time the red LED turns ON. Crawford Dock-IN White & Red guide the truck driver in the best possible way for an easy and safe docking.

#### 1.8.7.4 Available Options

- **Indication Light Inside**, built into the 950 control box  
 A Green LED light on the control box to indicate that the control box functions are released. The operator of the loading bay equipment knows exactly when he can start loading or unloading. The green LED light will help to save energy and to control the complete loading process.
- **Second Red LED**  
 A second Red LED bar can be added to have the red LED traffic light on both sides of the docking bay. This is an option for terminals with left and right hand drive international trucks.
- **Wheel chock connection**  
 To increase the safety it is possible to connect the Crawford wheel chock to the traffic light function Crawford Dock-IN Red or Crawford Dock-IN White and Red. The control box will be interlocked until the truck is detected and the wheel chock is in place.

Note:

Make sure the LED bars will not be covered by the Dock shelter.

Lowest possible truck is max. 2000 mm below the sensor position.

## 2. Selection guide

### 2.1 Load capacity according to EN 1398

The EN 1398 describes 3 key definitions about loads.

#### 2.1.1 Rated load

The rated load is the total weight of the goods, the forklift truck and the driver.

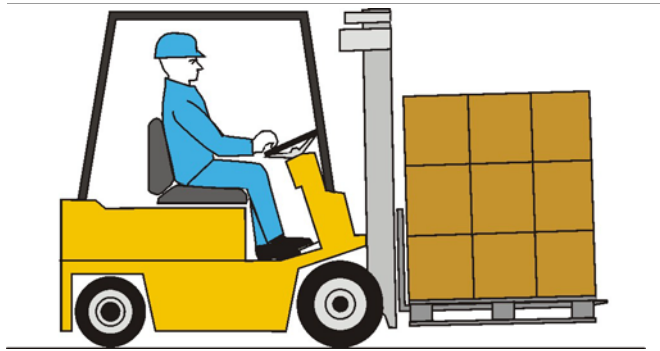

#### 2.1.2 Axle load

Axle loads shall be taken acting over two rectangular contact areas at 1 m lateral distance. These areas shall only apply if the actual conditions do not call for more severe loading. The size of the footprint [mm<sup>2</sup>] is derived from the wheel load [N] divided by 2 [N/mm<sup>2</sup>]. The ratio of the rectangular print is W:L = 3:2.

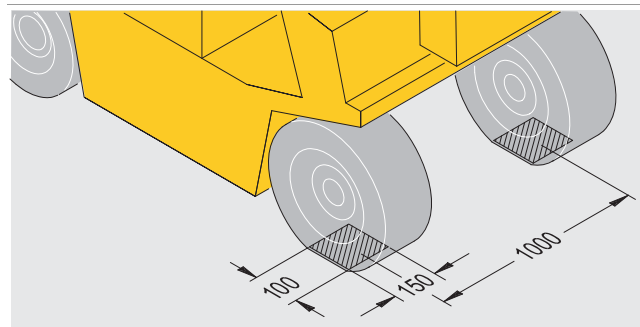

In the drawing measures for a leveller with a load capacity of 60kN are shown.

#### 2.1.3 Dynamic load

The dynamic load is the movement of the rated load and is the pressure on the leveller platform caused by the moving forklift truck.

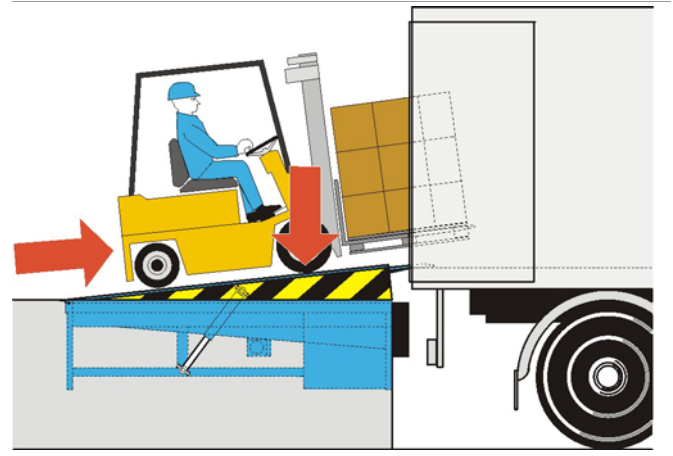

### 2.2 Select the load capacity

The load capacity of a dock leveller must always be higher than the rated load.

#### 2.2.1 Example

Weight of forklift truck	3600 kg
Weight of goods	1500 kg
Weight of driver	100 kg
Total weight/rated load	5200 kg
Suitable load capacity of the leveller	6000 kg/60kN

## 2.3 Select the appropriate platform tear plate thickness

The 6 tonnes (60kN) DL6010S swingdock is as a standard equipped with a tear plate of 6 mm (6/8). Optionally an 8 mm (8/10) tearplate is available.

### 2.3.1 Handling equipment traffic situation

Each handling-equipment traffic situation creates a certain point load impact on the dock leveller platform depending on the contact area of the wheels. The typical 4 wheel pneumatic-tired forklift trucks have a lower point load impact than electric pallet trucks with small hard wheels.

### 2.3.2 Example

Vehicle	Rated load	Point load	Tear plate	Load capacity
Roll cage	750 kg	Medium	6 mm	60 kN
Hand pallet truck	3200 kg	High	8 mm	60 kN
Electric pallet truck	3200 kg	High	8 mm	60 kN
Forklift truck	5200 kg	Medium	6 mm	60 kN

## 2.4 Select the leveller length

When determining the leveller length, measure the maximum height difference between the truck bed and the dock level. Next, determine which vehicles will be used and lookup the maximum gradient the vehicles are allowed to be used on.

Vehicle	Max gradient
Roll cage	3%
Hand pallet truck	3%
Electric pallet truck	7%
Forklift truck (battery)	10%
Forklift truck (gas / petrol)	15%

### 2.4.1 The calculation

Minimal leveller length = height difference / gradient (%)

### 2.4.2 Example

Vehicle:	Electric pallet truck (max 7% gradient)
Truck height:	1350 – 1000 mm
Dock height:	1150 mm

The difference between Truck height and Dock height  
 = 175 mm

175 mm / 7% = 2500 mm leveller length

## 2.5 Nominal width

The Crawford DL6010S swingdock is available with a nominal width of 1750, 2000 mm or 2200 mm. The correct nominal width must exceed the widest loading vehicle by at least 700 mm.



## 3. Specifications

### 3.1 Dimensions

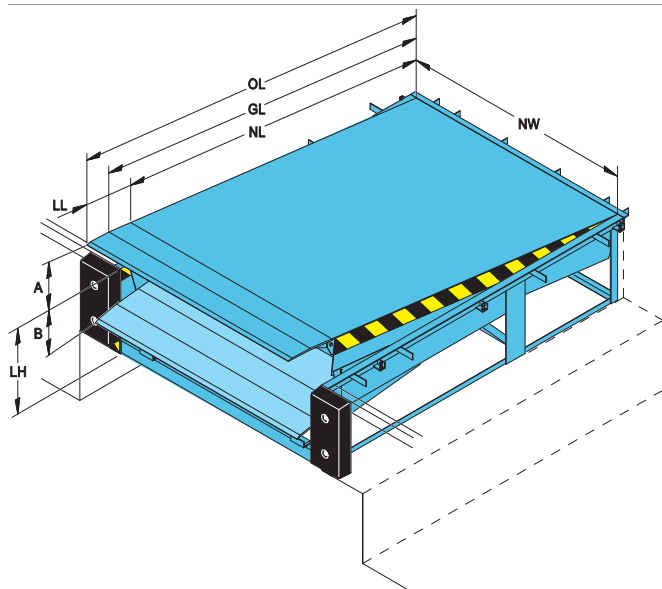

NL Nominal length

OL Overall length

GL Gradient length

NW Nominal width

LL Lip length

LH Leveller height

A Working range above dock level

B Working range below dock level

Dimensions				Vertical working range			
				LL 400		LL 500	
NL	OL	GL	LH	A	B	A	B
2000	NL+330	NL+190	600	260	280	-	-
	NL+330	NL+190	700	290	330	180	360
2250	NL+330	NL+190	600	290	275	-	-
	NL+330	NL+190	700	300	345	180	380
2500	NL+330	NL+190	600	310	270	-	-
	NL+330	NL+190	700	390	340	270	360
2770	NL+330	NL+190	600	335	270	-	-
	NL+330	NL+190	700	400	340	290	360
3000	NL+330	NL+190	600	340	265	-	-
	NL+330	NL+190	700	400	335	280	290
3500	NL+330	NL+190	800	495	335	390	345
4000	NL+330	NL+190	900	540	335	430	345
4500	NL+330	NL+190	900	590	335	480	345

Nominal width (NW) 1750, 2000, 2200.

### 3.2 Platform thickness

Thickness	Max. point load
6 mm	1,3 N / mm <sup>2</sup>
8 mm	6,5 N / mm <sup>2</sup>

## 3.3 Control units

### 3.3.1 Dimensions



950 Series

### 3.3.2 Functions

	LSD	LA SD	DLA SD	LSA SD	DLSA SD
Hold-to-run button	<input checked="" type="checkbox"/>	<input checked="" type="checkbox"/>	<input checked="" type="checkbox"/>	<input checked="" type="checkbox"/>	<input checked="" type="checkbox"/>
Impulse auto button	<input type="checkbox"/>	<input checked="" type="checkbox"/>	<input checked="" type="checkbox"/>	<input checked="" type="checkbox"/>	<input checked="" type="checkbox"/>
Mains isolator	<input checked="" type="checkbox"/>	<input checked="" type="checkbox"/>	<input checked="" type="checkbox"/>	<input checked="" type="checkbox"/>	<input checked="" type="checkbox"/>
Emergency stop button	<input type="checkbox"/>	<input type="checkbox"/>	<input type="checkbox"/>	<input type="checkbox"/>	<input type="checkbox"/>
400 V	<input checked="" type="checkbox"/>	<input checked="" type="checkbox"/>	<input checked="" type="checkbox"/>	<input checked="" type="checkbox"/>	<input checked="" type="checkbox"/>
230 V	<input type="checkbox"/>	<input type="checkbox"/>	<input type="checkbox"/>	<input type="checkbox"/>	<input type="checkbox"/>
Maintenance indicator	<input checked="" type="checkbox"/>	<input checked="" type="checkbox"/>	<input checked="" type="checkbox"/>	<input checked="" type="checkbox"/>	<input checked="" type="checkbox"/>
3 Digit display	<input checked="" type="checkbox"/>	<input checked="" type="checkbox"/>	<input checked="" type="checkbox"/>	<input checked="" type="checkbox"/>	<input checked="" type="checkbox"/>
Memory function	<input checked="" type="checkbox"/>	<input checked="" type="checkbox"/>	<input checked="" type="checkbox"/>	<input checked="" type="checkbox"/>	<input checked="" type="checkbox"/>
Connection to Crawford Monitoring System	<input type="checkbox"/>	<input type="checkbox"/>	<input type="checkbox"/>	<input type="checkbox"/>	<input type="checkbox"/>
BUS network interface	<input type="checkbox"/>	<input type="checkbox"/>	<input type="checkbox"/>	<input type="checkbox"/>	<input type="checkbox"/>
Crawford eye	<input type="checkbox"/>	<input type="checkbox"/>	<input type="checkbox"/>	<input type="checkbox"/>	<input type="checkbox"/>
Wheel chock	<input type="checkbox"/>	<input type="checkbox"/>	<input type="checkbox"/>	<input type="checkbox"/>	<input type="checkbox"/>
Door control	<input type="checkbox"/>	<input type="checkbox"/>	<input checked="" type="checkbox"/>	<input type="checkbox"/>	<input checked="" type="checkbox"/>
Shelter control	<input type="checkbox"/>	<input type="checkbox"/>	<input type="checkbox"/>	<input checked="" type="checkbox"/>	<input checked="" type="checkbox"/>
Fault indicator	<input type="checkbox"/>	<input type="checkbox"/>	<input type="checkbox"/>	<input type="checkbox"/>	<input type="checkbox"/>
Integrated clock	<input type="checkbox"/>	<input type="checkbox"/>	<input type="checkbox"/>	<input type="checkbox"/>	<input type="checkbox"/>

Standard  
 Option / Available

## 4. CEN Performance

### 4.1 Safety according to the European Standard EN 1398

- Emergency Stop Function.
  - Safety valves block lowering movement after max. 6% of the nominal length of the leveller.
  - Two lift cylinders make sure the leveller stops in a horizontal position.
- Free floating position.
- Platform torsion. Lateral deflection of at least 3% of nominal width.
- Toe guards cover gap between platform and pit in leveller's highest position.
- Working range gradient max. 12,5% (~7°).
- Warning stripes on side plates and on frame (black/yellow).

## 5. Building and space requirements

### 5.1 Electrical preparations

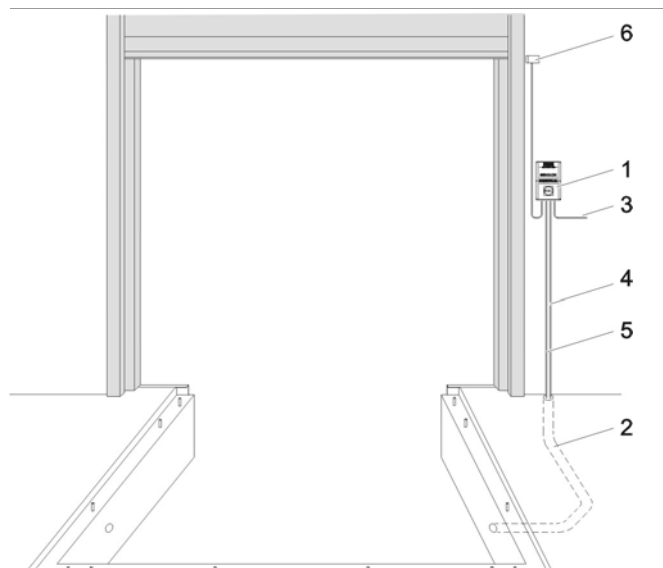

1	Control unit (included in the delivery)
2	Conduit for wiring internal diameter 70, angles <math><45^\circ</math> (by others)
3	Mains supply: 3/N/PE AC 50 Hz 230/400V Mains fuse: D0 10 A gL Motor power: 0,75 kW
4	Cable: 7 x 0,75 mm <sup>2</sup>
5	Motor cable: 4 x 1,5 mm <sup>2</sup>
6	Optional safety switch on sectional door to disable leveller when door is closed*

\*Non standard

## 5.2 Pit preparations

This section illustrates the required pit preparations for each frame type for the Crawford DL6010S swingdock.

### 5.2.1 T - frame + T-frame 200

**With tail lift recess**

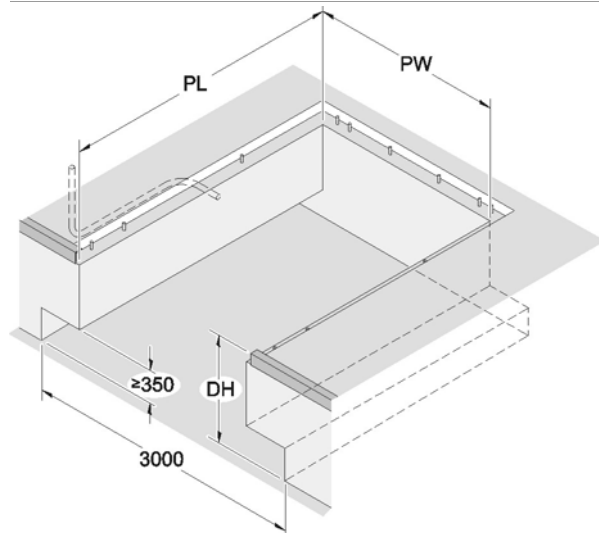

pit drawing 5143.0175

**Without tail lift recess**

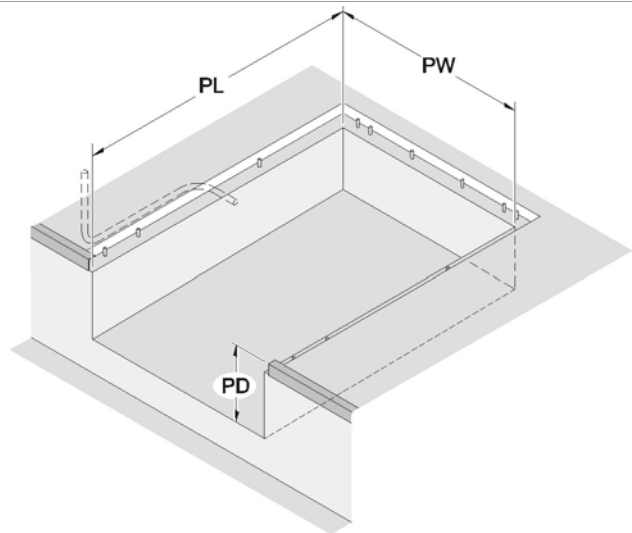

pit drawing 5143.0184

### 5.2.2 W - frame

**With tail lift recess**

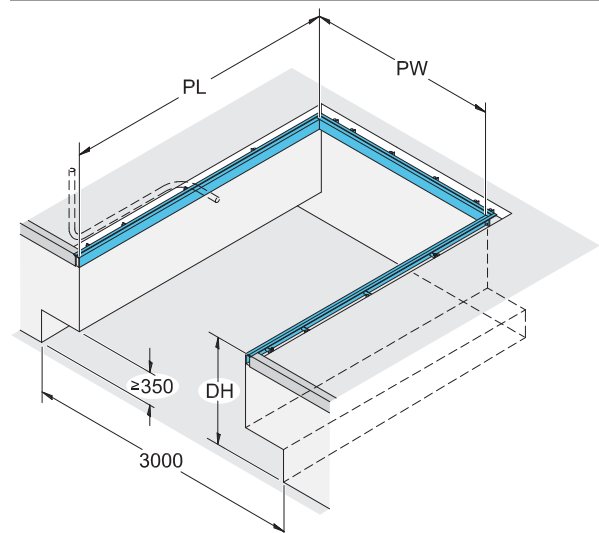

pit drawing 5143.0210

**Without tail lift recess**

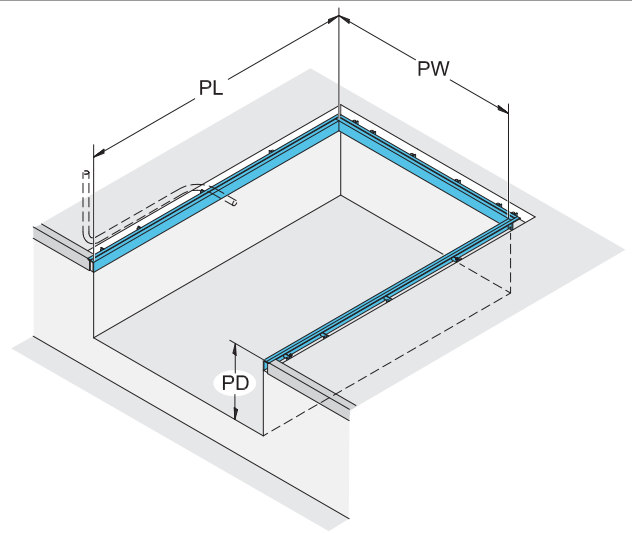

pit drawing 5143.0233

5.2.3 F - frame

With tail lift recess

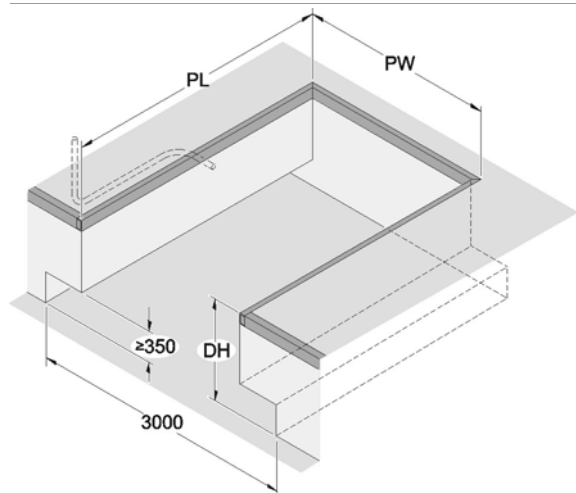

pit drawing 5143.0177

Without tail lift recess

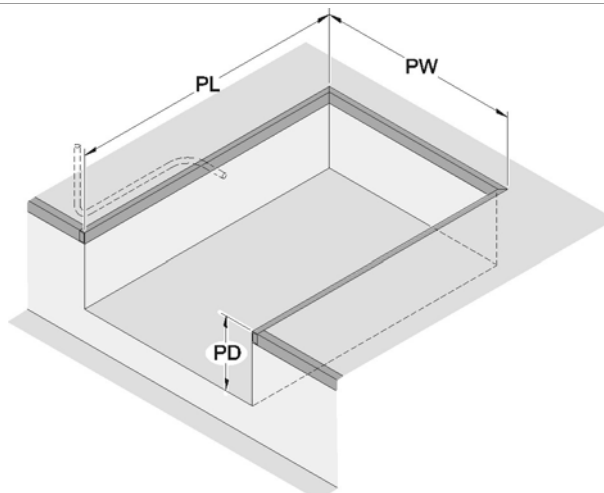

pit drawing 5143.0186

5.2.4 P - frame

With tail lift recess

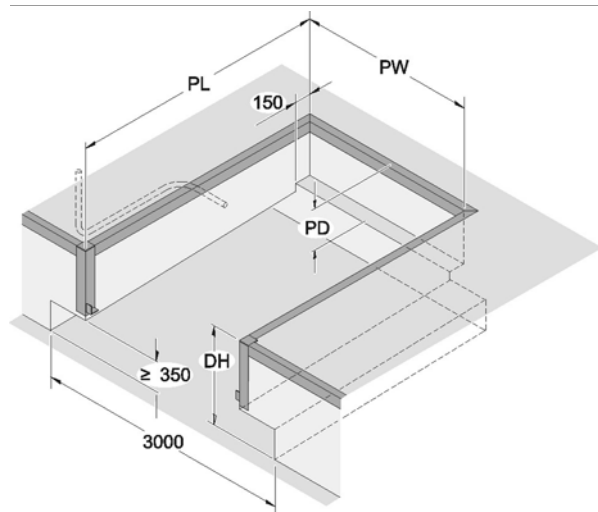

pit drawing 5143.0180

Without tail lift recess

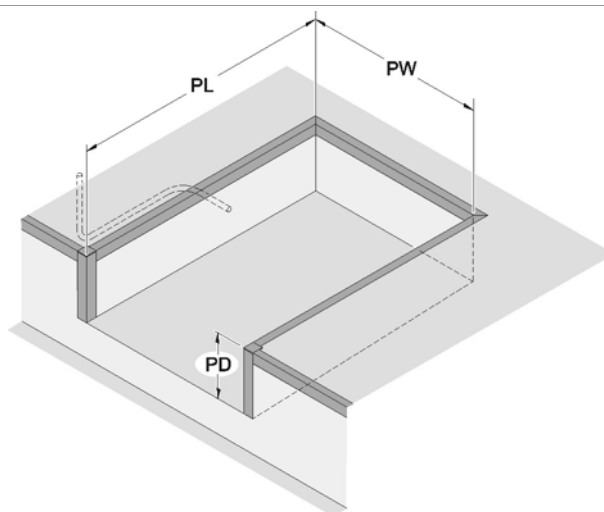

pit drawing 5143.0185

5.2.5 B - frame

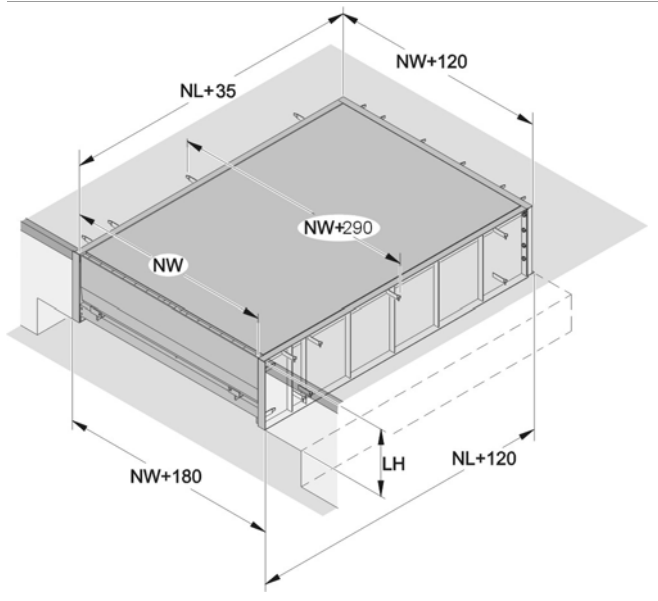

# 6. Service

## Preventive Maintenance Program and Modernization Services

As your entrances are part of your business flow, there's every reason to keep them working well. ASSA ABLOY Entrance Systems offers you a maintenance and modernization expertise to rely on. Our Maintenance Programs and Modernization Services are backed by a extensive expertise for all types of industrial door and docking systems, independent of brand. At your disposal is a team of dedicated expert technicians, proven through decades of maintenance, service and satisfied customers.

### Preventive Maintenance Programs

Minimizing lost time, lost energy and unexpected hassle is our team's constant objective. Our service organization can support you 24/7 in maintaining all industrial door and docking systems, independent of brand. If you want to be one step ahead of break-downs, explore our portfolio of Pro-Active Care plans. Naturally, we also offer entrance upgrades to suit your specific wishes and business needs.

### Pro-Active Care - Maintenance plans to fit your business

Regular maintenance can extend the lifetime of your equipment and help prevent unexpected problems. Our technician arrives on-site equipped with the knowledge and tools to service all automatic entrances, independent of brand.

- **Pro-Active Bronze**

The base on which all Pro-Active Plans are built provides the security of knowing that your equipment is regularly inspected and certified for safety, as well as performing optimally. It includes a number of planned on-site visits depending on your needs. Any unplanned service calls required during the term of the contract (including labor, travel and parts) are billed at special Pro-Active Care prices.

- **Pro-Active Silver**

This plan provides all the benefits of Pro-Active Bronze with the added advantage of labor and travel being included for service calls during regular business hours. The only additional charge would be for any parts that may be needed throughout the term of the contract.

- **Pro-Active Gold**

This plan provides the ultimate protection for your automatic entrance investment. It includes all the benefits of Pro-Active Silver, plus replacement of any parts required during an unplanned repair or planned maintenance visit. Pro-Active Gold is an excellent way to budget your automatic door expenses annually.

- **Pro-Active Tailor-Flex**

Our most flexible maintenance and service offering. The Pro-Active Care plan is designed by you, our customer. The plan allows you to balance your maintenance expenses against your real-world budget and presents the option to add or delete a number of maintenance elements to suit your budget goals, while meeting your overall performance and safety needs.

### Modernization

Your entrances are a long-term investment, from which you always want the best. Products develop over time, so do regulations and your business. Let us help you increase energy savings and meet today's standards. We provide advice and modernization kits for outdated installations, ensuring your investment meet requirements and performs optimally for many more years to come.

Re-Active Service		Pro-Active Care				
Corrective	SafetyCheck	Pro-Active Bronze	Pro-Active Silver	Pro-Active Gold	Pro-Active Tailor Flex	
		○	○	○	●	Other customized requests such as Response Time, Performance InfoPack and Advanced User Training
		○	○	●	○	Replacement of worn parts according to preventive Consumable Exchange Program
		○	○	●	○	Replacement of spare parts on breakdowns
		○	●	●	○	Travel and labor for additional call-out visits
		●	●	●	●	Preventive maintenance visits 1-4 times per year
		●	●	●	●	Travel and labor for preventive maintenance visits
		●	●	●	●	Response time and priority on call-outs <24h
		●	●	●	●	Preventive planned maintenance that meets the most demanding standards in the market
	●	●	●	●	●	Safety and quality checks according to applicable regulations and norms. Documentation of test results provided
●	●	●	●	●	●	Documentation of equipment status, assessment and service provided, all generated on site
●	●	●	●	●	●	Highly trained professional technicians with extensive knowledge, state-of-the-art tools and the right spare parts*
●	●	●	●	●	●	Dedicated Professional Customer Care Hotline

● = Included as standard

○ = Available at special prices

\* Well-stocked service vehicles with genuine and new spare parts



# Index

## Numerics

950 Docking DLA SD .....	11
950 Docking DLSA SD .....	11
950 Docking L SD .....	11
950 Docking LA SD .....	11
950 Docking LSA SD .....	11

## A

Application .....	6
Available Options .....	14
Axle load .....	15

## B

B - box-frame .....	10
B - frame .....	23
Bent lip .....	7
Bevelled lip .....	7
Buffers .....	12
Building and space requirements ...	20

## C

CEN Performance .....	19
Colours .....	9
Control units .....	18
Copyright and Disclaimer Notice .....	2
Crawford DE6090DI Dock-IN .....	14
Crawford DE6090DL Dock light Heavy Duty LED .....	14
Crawford DE6090E Eye .....	13
Crawford DE6090TS Traffic light system	13
Crawford DE6090WC Wheel chock	13

## D

Description .....	6
Dimensions .....	17, 18
Dock management .....	12
Dock-IN Red .....	14
Dock-IN White .....	14
Dock-IN White & Red .....	14
Docking control systems .....	11
Dynamic load .....	15

## E

EBF .....	13
EBH .....	13
Electrical preparations .....	20
EPDM seal .....	8
Equipment .....	12
Example .....	15, 16

## F

F - flat frame for welding .....	10
F - frame .....	22
Facility management .....	12
Features .....	3
Fold down segments .....	7
Frames - connection to building .....	9
Functions .....	18

## G

General .....	6
---------------	---

## H

Handling equipment traffic situation	16
Hot galvanising .....	9

## L

Lip angles .....	7
Lip shapes .....	7
Load capacity according to EN 1398	15

## M

Mode of operation .....	6
Monitoring systems .....	12

## N

Nominal width .....	16
---------------------	----

## O

Options .....	6
Overview .....	6

## P

P - frame .....	22
P - pit frame for welding .....	10
Paint classes .....	9
Painting .....	9
Parking guides .....	14
Performance .....	3
Pit preparations .....	21
Platform .....	8
Platform insulation .....	8
Platform tear-plate thickness .....	8
Platform thickness .....	17

## R

Rated load .....	15
RB .....	12
RB with steel front and top plate ...	13
RB with steel front plate .....	12
RS .....	12

## S

Safety according to the European Standard EN 1398 .....	19
Saving energy .....	12
Security enhancement .....	12
Select the appropriate platform tear plate thickness .....	16
Select the leveller length .....	16
Select the load capacity .....	15
Selection guide .....	15
Service .....	24
Slip protection / noise reduction .....	8
Specifications .....	17
Standard .....	6
Standard paint class .....	9
Standard swing lip .....	7
Steel spring buffer 600 .....	13
Steel spring buffer 800 .....	13
Straight lip .....	7
Surface .....	9
Swing Lip .....	7

T

T - 200 leveller frame for embedding in concrete .....	9
T - frame + T-frame 200 .....	21
T - leveller frame for embedding in concrete .....	9
Tapered swing lip .....	7
Technical facts .....	3
The calculation .....	16
Toe guards .....	8

W

W - frame .....	21
W - leveller frame for welding .....	10



ASSA ABLOY Entrance Systems is a leading supplier of entrance automation solutions for efficient flow of goods and people. With our globally recognized product brands Besam, Crawford, Megadoor and Albany, we offer products and services dedicated to satisfying end-user needs for safe, secure, convenient and sustainable operations.  
ASSA ABLOY Entrance Systems is a division within ASSA ABLOY.

**ASSA ABLOY**

[assaabloyentrance.com](http://assaabloyentrance.com)

Q2.0 - 2014



ASSA ABLOY Entrance Systems

Tel: +46 (0)10 4747 000  
[sales.aaes@assaabloy.com](mailto:sales.aaes@assaabloy.com)  
[assasabloyentrance.com](http://assasabloyentrance.com)