

# Product datasheet

Dock leveller  
Crawford DL6010SM

**ASSA ABLOY**

ASSA ABLOY Entrance Systems

The global leader in  
door opening solutions



# Copyright and Disclaimer Notice

Although the contents of this publication have been compiled with the greatest possible care, ASSA ABLOY Entrance Systems cannot accept liability for any damage that might arise from errors or omissions in this publication. We also reserve the right to make appropriate technical modifications/replacements without prior notice.

No rights can be derived from the contents of this document.

Color guides: Color differences may occur due to different printing and publication methods.

ASSA ABLOY, Besam, Crawford, Megadoor and Albany, as words and logos, are examples of trademarks owned by ASSA ABLOY Entrance Systems or companies within the ASSA ABLOY Group.

Copyright © ASSA ABLOY Entrance Systems AB 2006-2014.

No part of this publication may be copied or published by means of scanning, printing, photocopying, microfilm or any other process whatsoever without prior permission in writing by ASSA ABLOY Entrance Systems.

All rights reserved.

# Technical facts

## Features

Size - nominal length	700 mm	
Sizes - nominal width	1250, 2000, 2200 mm	
Vertical working range	Above dock:	0 - 100 mm
	Below dock:	0 - 100 mm
Lip material:	Steel	
Surface treatment:	Standard:	RAL 5010
	Option:	RAL 3002
		RAL 6005
		RAL 9005
		Hot dip galvanised

## Performance

Load capacity:	4 tonnes (40kN) 6 tonnes (60kN)
Surface treatment paint class 3:	160 µm Corrosive Category C3 M acc. DIN EN ISO 12944-2
Surface treatment galvanised:	Hot dip galvanised 80 µm Corrosive category C4 & C5-I M acc. DIN EN ISO 12944-2

# Contents

Copyright and Disclaimer Notice .....	2
Technical facts .....	3
Contents .....	4
1. Description .....	5
1.1 General .....	5
1.1.1 Application .....	5
1.1.2 Mode of operation .....	5
1.1.3 Overview .....	5
1.1.4 Standard .....	5
1.1.5 Options .....	5
1.2 Surface .....	6
1.2.1 Painting .....	6
1.2.2 Hot galvanising .....	6
2. Selection guide .....	7
2.1 Load capacity according to EN 1398 .....	7
2.1.1 Rated load .....	7
2.1.2 Axle load .....	7
2.1.3 Dynamic load .....	7
2.2 Select the load capacity .....	7
2.2.1 Example .....	7
3. Specifications .....	8
3.1 Dimensions .....	8
4. Installation .....	9
4.1 Ramp installation .....	9
4.1.1 Buffer options .....	9
4.2 Pit installation .....	10
4.2.1 Without tail lift recess .....	10
4.2.2 With tail lift recess .....	10
4.2.3 Buffer options .....	11
5. Service .....	12
Index .....	13

# 1. Description

## 1.1 General

### 1.1.1 Application

The Crawford DL6010SM minidock is a full Docking System especially developed for a limited working range, the ideal solution for a standardized fleet of vehicles. It is available as ramp model as well as pit model. The advantage of the ramp model is the quick installation which also can be done as add-on to existing ramps. The operation of the Crawford DL6010SM minidock is mechanically and supported by a gas spring. You need only one person to lift the platform, swing out, and put the lip on the vehicle bed in one movement. The Crawford DL6010SM minidock solution include the free floating position, the platform follow the vehicle's movements up and down during loading and unloading.

The dock leveller type Crawford DL6010SM minidock meets all requirements of European directive EN 1398.

### 1.1.2 Mode of operation

The swing lip safely bridges the gap between the ramp and the lorry bed. By manually pulling the rod, the dock leveller is raised and the lip swings out. Then the leveller can be lowered gently onto the lorry bed. After loading or unloading, pulling the rod raises the leveller again, the lip swings down and the platform returns to its parking position, i.e. to ramp level.

### 1.1.3 Overview

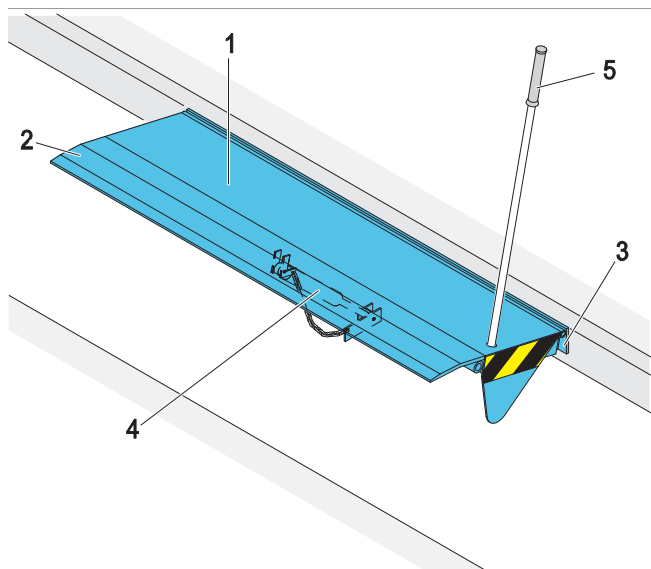

- 1 Leveller platform
- 2 Swing lip
- 3 Rear frame
- 4 Gas spring

### 1.1.4 Standard

Nominal length:	700 mm
Nominal width:	1250, 2000, 2200 mm
Load capacity:	4 tonnes (40 kN)
Surface	Painting RAL 5010
Installation:	Ramp installation (steel support construction for buffers included)

### 1.1.5 Options

Load capacity:	6 tonnes (60 kN) (only available for nominal width 2000, 2200 mm)
Surface	Painting RAL 3002, RAL 6005 or RAL 9005 Hot galvanised
Installation:	Pit installation
Equipment:	Buffer RB Buffer RB with steel protection plate Buffer RB/2

## 1.2 Surface

### 1.2.1 Painting

#### 1.2.1.1 Colours

The dock leveller standard finish is painted. The standard colour is:



---

Colours available as option are:



#### 1.2.1.2 Standard paint class

If the dock leveller is to be used in a rural area, the standard finish is:

- Paint class 2; 120 µm factory painted for corrosive category C2 M

#### 1.2.1.3 Paint classes

If the dock leveller is to be used in an urban or industrial atmosphere, or in a coastal area, it may be appropriate to select an alternative paint class with increased resistance to corrosion C3 M.

- Paint class 3; 160 µm factory painted for corrosive category C3 M

### 1.2.2 Hot galvanising

To increase corrosion protection to C4 for saline coastal areas or C5-I for aggressive or humid atmospheres, the dock leveller can be delivered with hot dip galvanised (80 µm) steel parts.

## 2. Selection guide

### 2.1 Load capacity according to EN 1398

The EN 1398 describes 3 key definitions about loads.

#### 2.1.1 Rated load

The rated load is the total weight of the goods, the forklift truck and the driver.



#### 2.1.2 Axle load

Axle loads shall be taken acting over two rectangular contact areas at 1 m lateral distance. These areas shall only apply if the actual conditions do not call for more severe loading. The size of the footprint [mm<sup>2</sup>] is derived from the wheel load [N] divided by 2 [N/mm<sup>2</sup>]. The ratio of the rectangular print is W:L = 3:2.

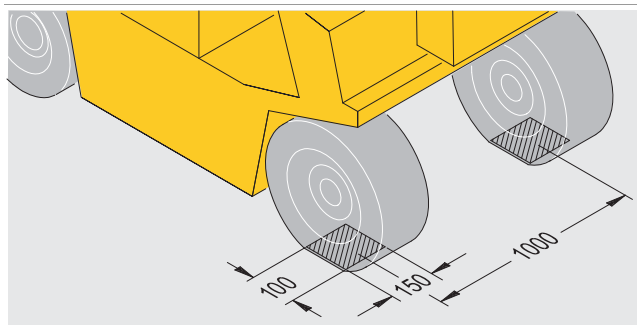

In the drawing measures for a leveller with a load capacity of 60kN are shown.

#### 2.1.3 Dynamic load

The dynamic load is the movement of the rated load and is the pressure on the leveller platform caused by the moving forklift truck.

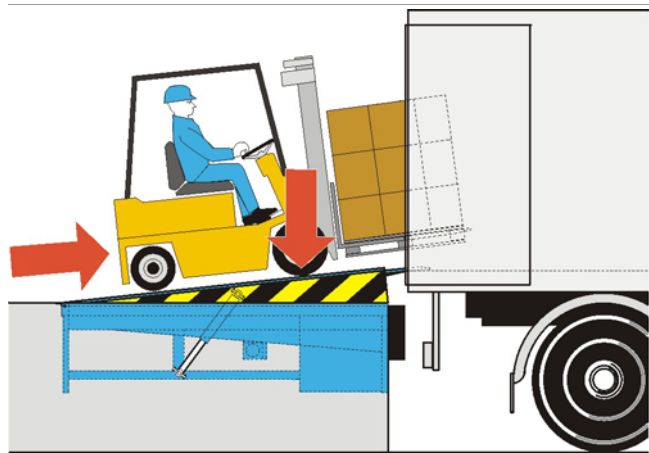

### 2.2 Select the load capacity

The load capacity of a dock leveller must always be higher than the rated load.

#### 2.2.1 Example

Weight of forklift truck	3600 kg
Weight of goods	1500 kg
Weight of driver	100 kg
Total weight/rated load	5200 kg
Suitable load capacity of the leveller	6000 kg/60kN

## 3. Specifications

### 3.1 Dimensions

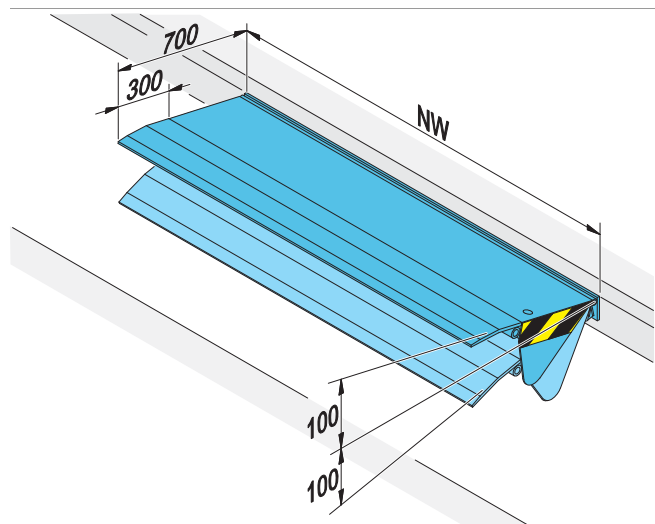

Nominal width	1250mm (40 kN) 2000mm (40 kN, 60 kN) 2200mm (40 kN, 60 kN)
Nominal length	700mm
Length of swing lip	300 mm
Vertical working range	100 mm



## 4. Installation

This section illustrates the two installation modes for the Crawford DL6010SM swingdock minidock.

- Ramp installation
- Pit installation

### 4.1 Ramp installation

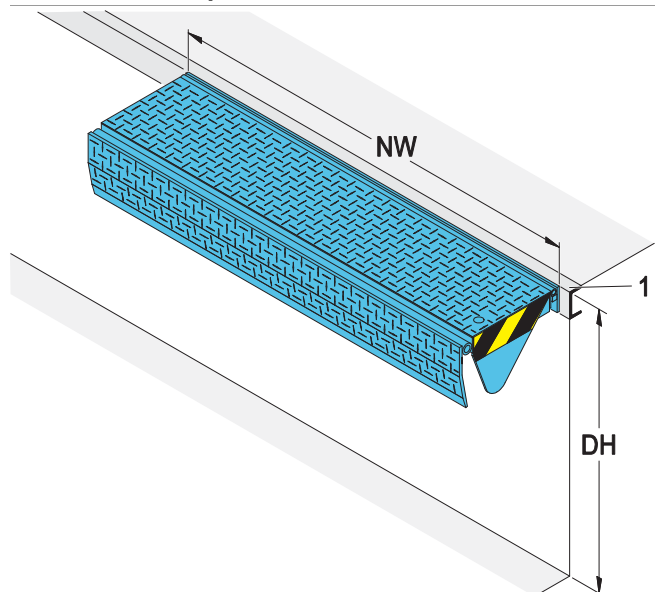

pit drawing 5143.0206	without tail lift recess
pit drawing 5143.0243	with tail lift recess
NW	Nominal width
DH	Dock height
1	Angle (by others)

#### 4.1.1 Buffer options

##### 4.1.1.1 RB/2: Buffer

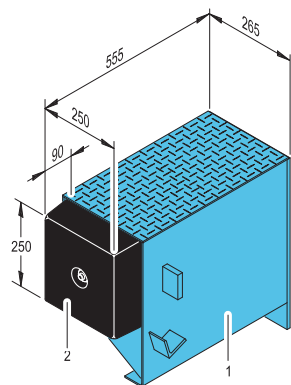

HxWxD = 500x265x555

1 steel support construction  
 2 buffer 250x250x90

##### 4.1.1.2 RB: Buffer

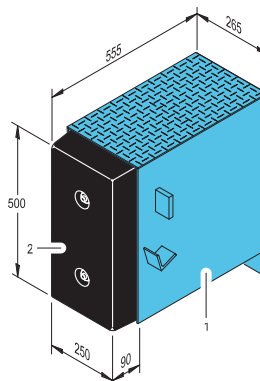

HxWxD = 500x265x555

1 steel support construction  
 2 buffer 500x250x90

##### 4.1.1.3 RB: Buffer with steel protection plate

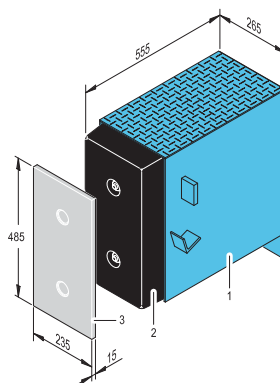

HxWxD = 500x265x555

1 steel support construction  
 2 buffer 500x250x90  
 3 buffer protection plate 485x235x15

##### 4.1.1.4 Bracket for steel support construction

Bracket for ramp installation with buffer construction RB 500x250x90 when the concrete cantilever plate is <370mm.

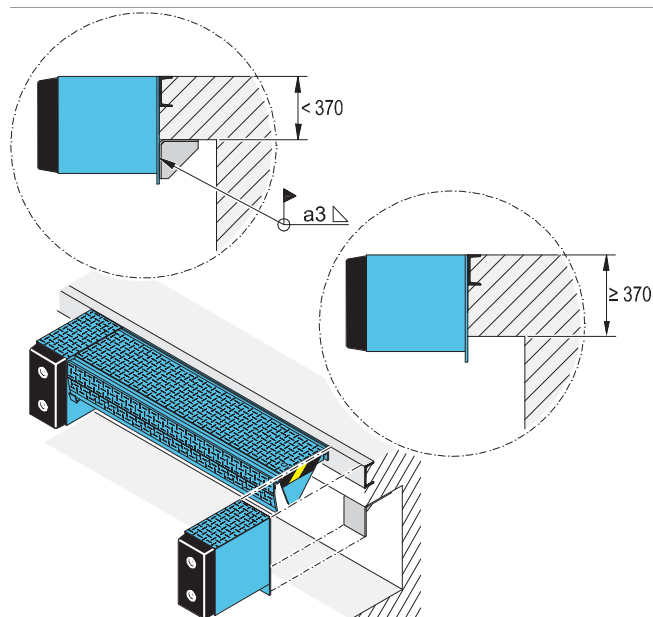

## 4.2 Pit installation

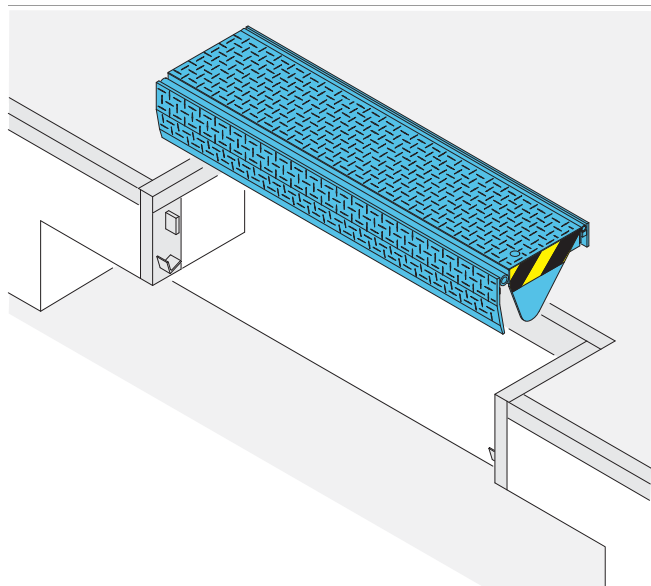

### 4.2.2 With tail lift recess

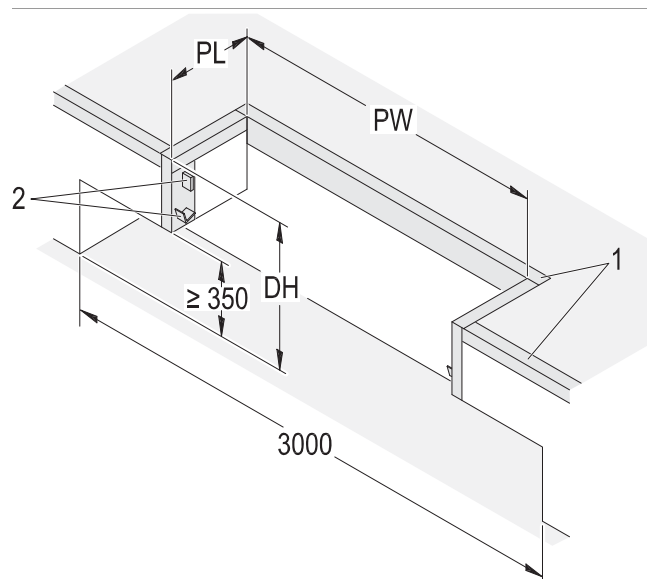

pit drawing 5143.0244

PL pit length

PW pit width

PD pit depth

DH dock height

1 angle (by others)

2 resting angles (by others)

### 4.2.1 Without tail lift recess

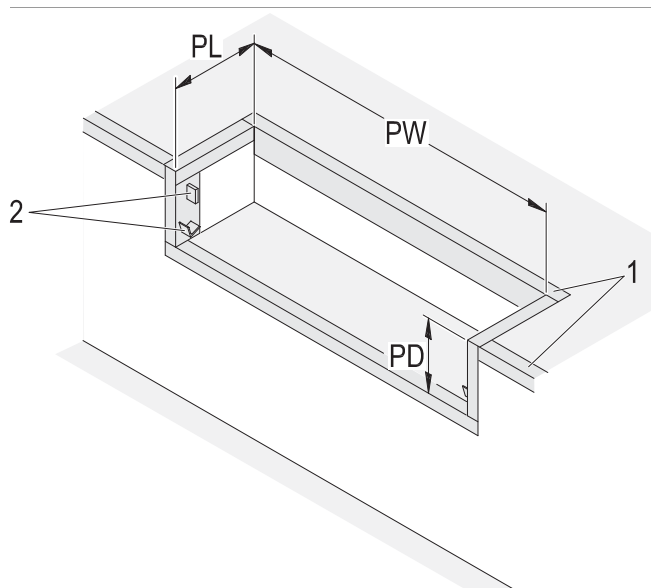

pit drawing 5143.0199

### 4.2.3 Buffer options

#### 4.2.3.1 RB/2: Buffer

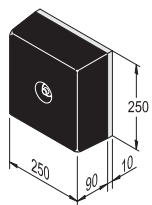

HxWxD = 250x250x90

1 buffer 250x250x90

#### 4.2.3.2 RB: Buffer

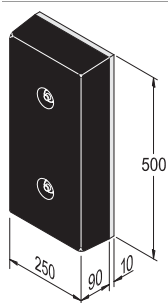

HxWxD = 500x250x90

1 buffer 500x250x90

#### 4.2.3.3 RB: Buffer with steel protection plate

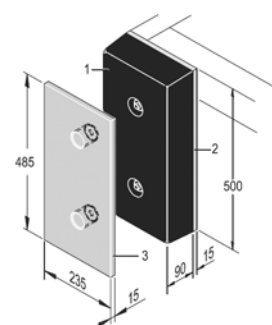

HxWxD = 500x250x105

1 buffer 500x250x90  
2 buffer protection plate  
485x235x15

# 5. Service

## Preventive Maintenance Program and Modernization Services

As your entrances are part of your business flow, there's every reason to keep them working well. ASSA ABLOY Entrance Systems offers you a maintenance and modernization expertise to rely on. Our Maintenance Programs and Modernization Services are backed by a extensive expertise for all types of industrial door and docking systems, independent of brand. At your disposal is a team of dedicated expert technicians, proven through decades of maintenance, service and satisfied customers.

### Preventive Maintenance Programs

Minimizing lost time, lost energy and unexpected hassle is our team's constant objective. Our service organization can support you 24/7 in maintaining all industrial door and docking systems, independent of brand. If you want to be one step ahead of break-downs, explore our portfolio of Pro-Active Care plans. Naturally, we also offer entrance upgrades to suit your specific wishes and business needs.

### Pro-Active Care - Maintenance plans to fit your business

Regular maintenance can extend the lifetime of your equipment and help prevent unexpected problems. Our technician arrives on-site equipped with the knowledge and tools to service all automatic entrances, independent of brand.

- **Pro-Active Bronze**

The base on which all Pro-Active Plans are built provides the security of knowing that your equipment is regularly inspected and certified for safety, as well as performing optimally. It includes a number of planned on-site visits depending on your needs. Any unplanned service calls required during the term of the contract (including labor, travel and parts) are billed at special Pro-Active Care prices.

- **Pro-Active Silver**

This plan provides all the benefits of Pro-Active Bronze with the added advantage of labor and travel being included for service calls during regular business hours. The only additional charge would be for any parts that may be needed throughout the term of the contract.

- **Pro-Active Gold**

This plan provides the ultimate protection for your automatic entrance investment. It includes all the benefits of Pro-Active Silver, plus replacement of any parts required during an unplanned repair or planned maintenance visit. Pro-Active Gold is an excellent way to budget your automatic door expenses annually.

- **Pro-Active Tailor-Flex**

Our most flexible maintenance and service offering. The Pro-Active Care plan is designed by you, our customer. The plan allows you to balance your maintenance expenses against your real-world budget and presents the option to add or delete a number of maintenance elements to suit your budget goals, while meeting your overall performance and safety needs.

### Modernization

Your entrances are a long-term investment, from which you always want the best. Products develop over time, so do regulations and your business. Let us help you increase energy savings and meet today's standards. We provide advice and modernization kits for outdated installations, ensuring your investment meet requirements and performs optimally for many more years to come.

Re-Active Service		Pro-Active Care				
Corrective	SafetyCheck	Pro-Active Bronze	Pro-Active Silver	Pro-Active Gold	Pro-Active Tailor Flex	
		○	○	○	●	Other customized requests such as Response Time, Performance InfoPack and Advanced User Training
		○	○	●	○	Replacement of worn parts according to preventive Consumable Exchange Program
		○	○	●	○	Replacement of spare parts on breakdowns
		○	●	●	○	Travel and labor for additional call-out visits
		●	●	●	●	Preventive maintenance visits 1-4 times per year
		●	●	●	●	Travel and labor for preventive maintenance visits
		●	●	●	●	Response time and priority on call-outs <24h
		●	●	●	●	Preventive planned maintenance that meets the most demanding standards in the market
	●	●	●	●	●	Safety and quality checks according to applicable regulations and norms. Documentation of test results provided
●	●	●	●	●	●	Documentation of equipment status, assessment and service provided, all generated on site
●	●	●	●	●	●	Highly trained professional technicians with extensive knowledge, state-of-the-art tools and the right spare parts*
●	●	●	●	●	●	Dedicated Professional Customer Care Hotline

● = Included as standard  
 ○ = Available at special prices  
 \* Well-stocked service vehicles with genuine and new spare parts

# Index

<b>A</b>		<b>R</b>	
Application .....	5	Ramp installation .....	9
Axle load .....	7	Rated load .....	7
<b>B</b>		RB	
Bracket for steel support construction	9	Buffer .....	9, 11
Buffer options .....	9, 11	Buffer with steel protection plate	9, 11
<b>C</b>		RB/2	
Colours .....	6	Buffer .....	9, 11
Copyright and Disclaimer Notice .....	2	<b>S</b>	
<b>D</b>		Select the load capacity .....	7
Description .....	5	Selection guide .....	7
Dimensions .....	8	Service .....	12
Dynamic load .....	7	Specifications .....	8
<b>E</b>		Standard .....	5
Example .....	7	Standard paint class .....	6
<b>F</b>		Surface .....	6
Features .....	3	<b>T</b>	
<b>G</b>		Technical facts .....	3
General .....	5	<b>W</b>	
<b>H</b>		With tail lift recess .....	10
Hot galvanising .....	6	Without tail lift recess .....	10
<b>I</b>			
Installation .....	9		
<b>L</b>			
Load capacity according to EN 1398	7		
<b>M</b>			
Mode of operation .....	5		
<b>O</b>			
Options .....	5		
Overview .....	5		
<b>P</b>			
Paint classes .....	6		
Painting .....	6		
Performance .....	3		
Pit installation .....	10		





ASSA ABLOY Entrance Systems is a leading supplier of entrance automation solutions for efficient flow of goods and people. With our globally recognized product brands Besam, Crawford, Megadoor and Albany, we offer products and services dedicated to satisfying end-user needs for safe, secure, convenient and sustainable operations.  
ASSA ABLOY Entrance Systems is a division within ASSA ABLOY.

**ASSA ABLOY**

[assaabloyentrance.com](http://assaabloyentrance.com)

Q2.0 - 2014

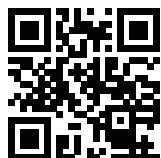

ASSA ABLOY Entrance Systems

Tel: +46 (0)10 4747 000  
[sales.aaes@assaabloy.com](mailto:sales.aaes@assaabloy.com)  
[assasabloyentrance.com](http://assasabloyentrance.com)